



APPROVAL SHEET

WW25P, WW20P, WW12P

±1%, ±5%

Thick Film High Power Low Ohm Chip Resistors

Size 2512 2W, 2010 1W, 1206 1/2W

*Contents in this sheet are subject to change without prior notice.



FEATURE

1. High power rating and compact size
2. High reliability and stability
3. Reduced size of final equipment
4. RoHS compliant and lead free products.

APPLICATION

- Power supply
- PDA
- Digital meter
- Computer
- Automotives
- Battery charger
- DC-DC power converter

DESCRIPTION

The resistors are constructed in a high grade ceramic body (aluminum oxide). Internal metal electrodes are added at each end and connected by a resistive paste that is applied to the top surface of the substrate. The composition of the paste is adjusted to give the approximate resistance required and the value is trimmed to nominated value within tolerance which controlled by laser trimming of this resistive layer.

The resistive layer is covered with a protective coat. Finally, the two external end terminations are added. For ease of soldering the outer layer of these end terminations is Tin (lead free) alloy.

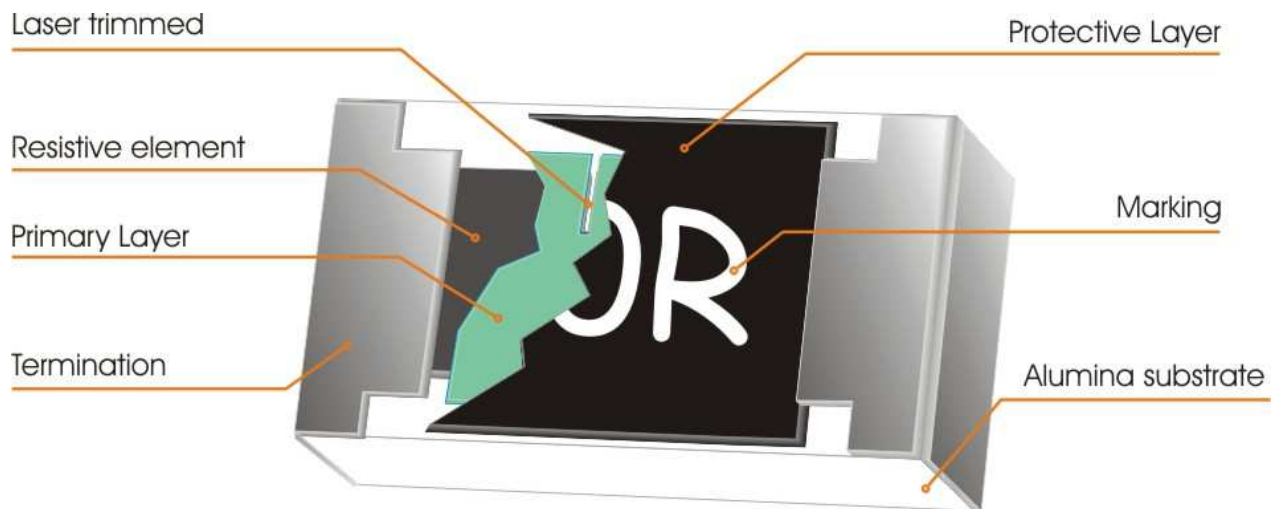

Fig 1. Construction of Chip-R

**QUICK REFERENCE DATA**

Item	General Specification		
	WW25P	WW20P	WW12P
Series No.	WW25P	WW20P	WW12P
Size code	2512 (6432)	2010 (5025)	1206 (3216)
Resistance Tolerance	±1%, ±5%		
Resistance Range	0.040Ω ~ 0.976Ω		0.020Ω ~ 0.976Ω
TCR (ppm/°C)	100mohm ~ 976mohm 47mohm ~ 97.6mohm 20 mohm ~ 43mohm	±100ppm ±150ppm ±200ppm	±100ppm ±150ppm ±200ppm ±1000ppm
Max. dissipation at T _{amb} =70°C	2 W	1 W	1/2 W
Max. Operation Voltage	300V	200V	200V
Max. Overload Voltage	500V	400V	400V
Climatic category (IEC 60068)	55/155/56		

Note :

1. This is the maximum voltage that may be continuously supplied to the resistor element, see "IEC publication 60115-8"
2. Max. Operation Voltage : So called RCWV (Rated Continuous Working Voltage) is determined by

$$RCWV = \sqrt{\text{Rated Power} \times \text{Resistance Value}}$$
or Max. RCWV listed above, whichever is lower.
3. 2W loading with total solder-pad and trace size of 300 mm²
4. Resistance value will be changed by soldering condition and design of soldering pad, please design products in consideration of this change of resistance value.

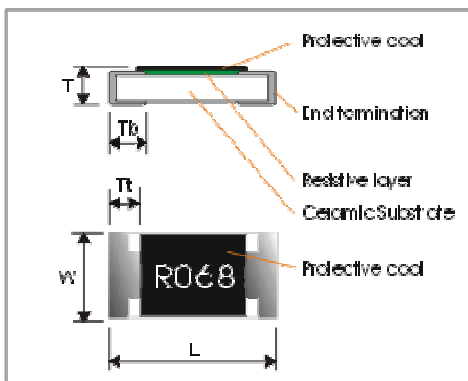
MECHANICAL DATA

Unit: mm

Symbol	WW25P	WW20P	WW12P
L	6.30 ± 0.20	5.00 ± 0.20	3.10 ± 0.15
W	3.10 ± 0.20	2.50 ± 0.20	1.60 ± 0.15
T	0.60 ± 0.15	0.60 ± 0.10	0.55 ± 0.10
T _t	0.60 ± 0.25	0.60 ± 0.25	0.50 ± 0.25
T _b	1.80 ± 0.25	0.60 ± 0.25	0.50 ± 0.25



Recommended Solder Pad Dimensions

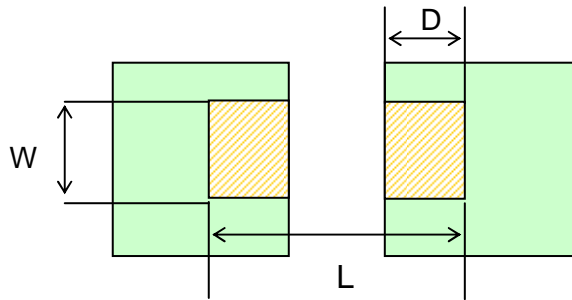

Type	W	D	L
WW25P	3.7mm	2.45mm	7.6mm

MARKING

Each resistor is marked with a four-digit code on the protective coating to designate the nominal resistance value.

Example:

R100 = 0.100Ω
R910 = 0.910Ω

FUNCTIONAL DESCRIPTION

Product characterization

Standard values of nominal resistance are taken from the E96 & E24 series for resistors with a tolerance of ±5% & ±1%. The values of the E24/E96 series are in accordance with "IEC publication 60063".

Derating curve

The power that the resistor can dissipate depends on the operating temperature; see Fig.2

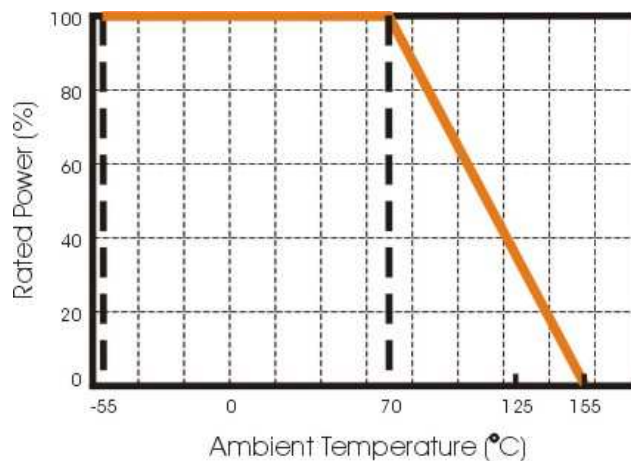

Figure 2 Maximum dissipation in percentage of rated power as a function of the ambient temperature

MOUNTING

Due to their rectangular shapes and small tolerances, Surface Mountable Resistors are suitable for handling by automatic placement systems.

Chip placement can be on ceramic substrates and printed-circuit boards (PCBs).

Electrical connection to the circuit is by individual soldering condition.

The end terminations guarantee a reliable contact.



SOLDERING CONDITION

The robust construction of chip resistors allows them to be completely immersed in a solder bath of 260°C for 10 seconds. Therefore, it is possible to mount Surface Mount Resistors on one side of a PCB and other discrete components on the reverse (mixed PCBs).

Surface Mount Resistors are tested for solderability at 235°C during 2 seconds. The test condition for no leaching is 260°C for 30 seconds. Typical examples of soldering processes that provide reliable joints without any damage are given in Fig 3.

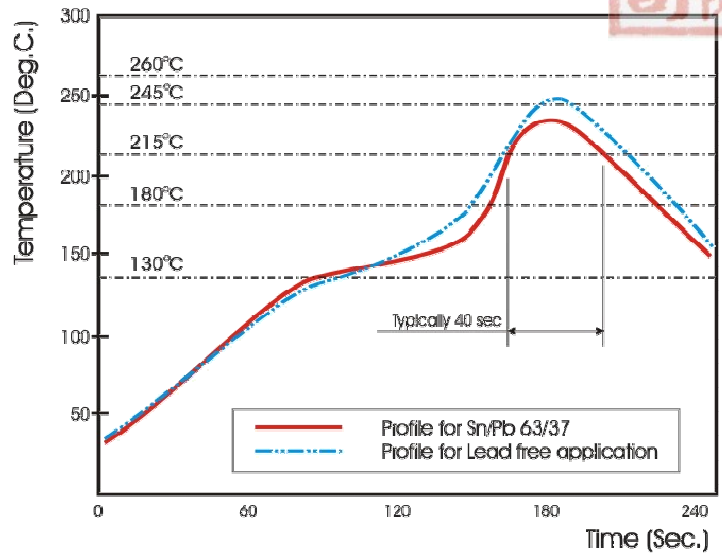

Fig 3. Infrared soldering profile for Chip Resistors

CATALOGUE NUMBERS

The resistors have a catalogue number starting with.

WW25	P	R100	J	T	L
Size code WW25 : 2512 WW20 : 2010 WW12 : 1206	Type code P :Power 2512 size=2 watt 2010 size=1 watt 1206 size=0.5 watt	Resistance code E96 +E24: "R" is first digit followed by 3 significant digits. e.g.: 0.1ohm = R100 0.047ohm = R047 0.56ohm = R560	Tolerance J : ±5% F : ±1%	Packaging code T : 7" Reel taping G : 13" Reel taping	Termination code L = Sn base (lead free)

Tape packaging WW12 : 8mm width paper taping 5,000pcs per 7" reel. 20,000pcs per 13" reel.

WW25 : WW20: 12mm width plastic taping 4,000pcs per reel.



TEST AND REQUIREMENTS

Basic specification : JIS C 5201-1 : 1998

TEST	PROCEDURE	REQUIREMENT
Clause 4.8 Temperature Coefficient of Resistance (TCR)	Natural resistance change per change in degree centigrade. $\frac{R_2 - R_1}{R_1(t_2 - t_1)} \times 10^6 \text{ (ppm/}^\circ\text{C)}$ R ₁ : Resistance at reference temperature R ₂ : Resistance at test temperature t ₁ : 20°C+5°C-1°C	Refer to quick reference data for T.C.R specification
Clause 4.13 Short time overload	Permanent resistance change after 5 second application of a power 5.0 times of rated power or the maximum overload voltage specified in the above list, whichever is less.	$\Delta R/R \text{ max. J: } \leq \pm(2\%+0.5\text{m}\Omega)$ $F: \leq \pm(1\%+0.5\text{m}\Omega)$
Clause 4.18 Resistance to soldering heat(R.S.H)	Un-mounted chips completely immersed for 10±1second in a SAC solder bath at 260°C±5°C	No visible damage $\Delta R/R \text{ max. J: } \leq \pm(1\%+0.5\text{m}\Omega)$ $F: \leq \pm(0.5\%+0.5\text{m}\Omega)$
Clause 4.17 Solderability	Un-mounted chips completely immersed for 2±0.5second in a SAC solder bath at 235°C±5°C	Good tinning (>95% covered) No visible damage
Clause 4.19 Temperature cycling	30 minutes at -55°C±3°C, 2~3 minutes at 20°C+5°C-1°C, 30 minutes at +155°C±3°C, 2~3 minutes at 20°C+5°C-1°C, total 5 continuous cycles	No visible damage $\Delta R/R \text{ max. J } \leq \pm(1\%+1\text{m}\Omega)$ $F \leq \pm(0.5\%+1\text{m}\Omega)$
Clause 4.25 Load life (endurance)	1000 +48/-0 hours, loaded with RCWV or Vmax in chamber controller 70±2°C, 1.5 hours on and 0.5 hours off	No visible damage $\Delta R/R \text{ max. J } \leq \pm(3\%+0.5\text{m}\Omega)$ $F \leq \pm(1\%+0.5\text{m}\Omega)$
Clause 4.24 Load life in Humidity	1000 +48/-0 hours, loaded with RCWV or Vmax in humidity chamber controller at 40°C±2°C and 90~95% relative humidity, 1.5hours on and 0.5 hours off	No visible damage $\Delta R/R \text{ max. J } \leq \pm(3\%+0.5\text{m}\Omega)$ $F \leq \pm(1\%+0.5\text{m}\Omega)$
Clause 4.33 Bending strength	Resistors mounted on a 90mm glass epoxy resin PCB(FR4); bending : 2 mm(2512;2010) 3mm(1206), once for 10 seconds	No visible damage $\Delta R/R \text{ max. J } \leq \pm(1\%+1\text{m}\Omega)$ $F \leq \pm(0.5\%+1\text{m}\Omega)$
Clause 4.32 Adhesion	Pressurizing force: 5N, Test time: 10±1sec	No remarkable damage or removal of the terminations
Insulation Resistance Clause 4.6	Apply the maximum overload voltage (DC) for 1minutes	R ≥ 10GΩ
Dielectric Withstand Voltage Clause 4.7	Apply the maximum overload voltage (AC) for 1 minutes	No breakdown or flashover



PACKAGING

Paper Tape(WW12P) & Plastic Tape(WW25P;WW20P) specifications (unit :mm)

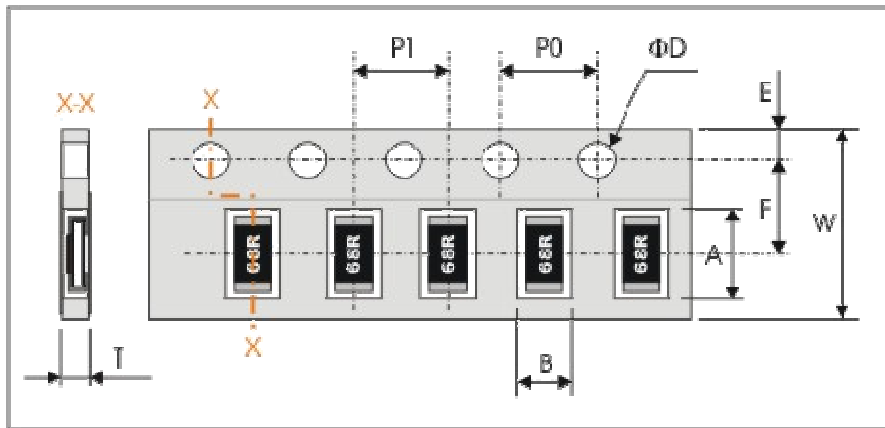

Series No.	A	B	W	F	E
WW25P	6.90±0.20	3.60±0.20	12.00±0.30	5.50±0.10	1.75±0.10
WW20P	5.50±0.20	2.80±0.20			
WW12P	3.60±0.20	2.00±0.20	8.00±0.30	3.50±0.20	

Series No.	P1	P0	ΦD	T
WW25P	4.00±0.10	4.00±0.10	Φ1.50 ^{+0.1} _{-0.0}	Max. 1.2
WW20P				Max. 1.0
WW12P				

Reel dimensions

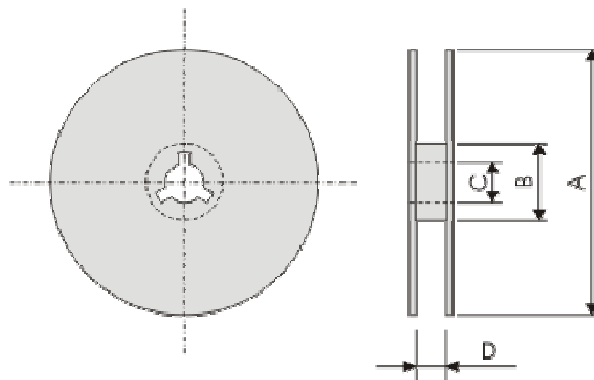

(unit : mm)

Reel / Tape	A	B	C	D
7" reel for 8mm tape	Φ178.0±2.0	Φ60.0±1.0	13.0±0.2	9.00±0.50
7" reel for 12mm tape				12.4±1.00
13" reel for 8mm tape	Φ330.0±2.00	Φ100.0±1.00	13.0±0.2	9.00±0.50